

PEDESTRIAN RAIL DETAIL

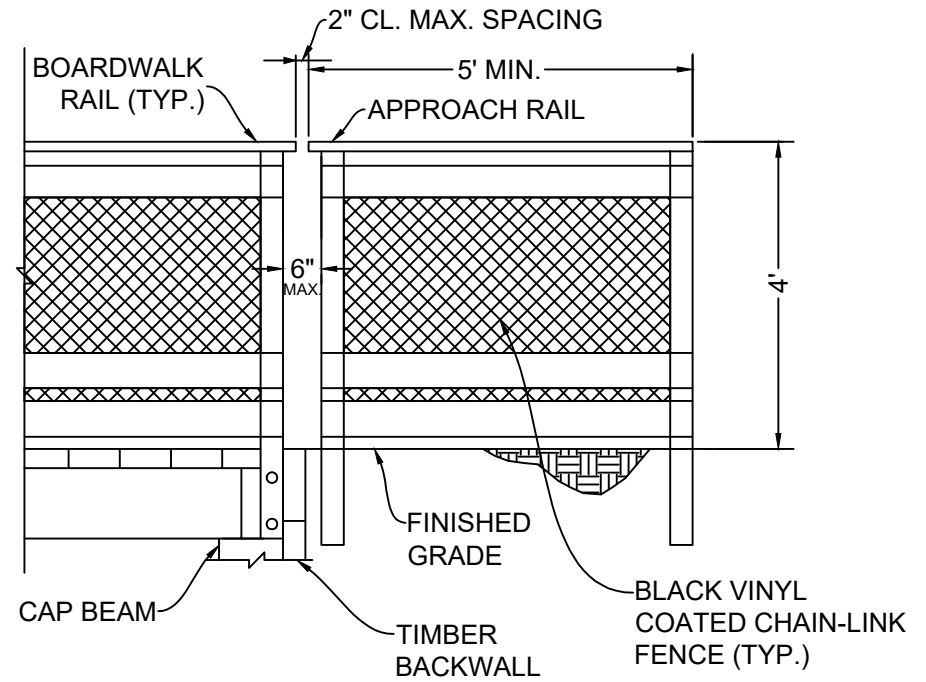

STANDARD RAIL DETAIL

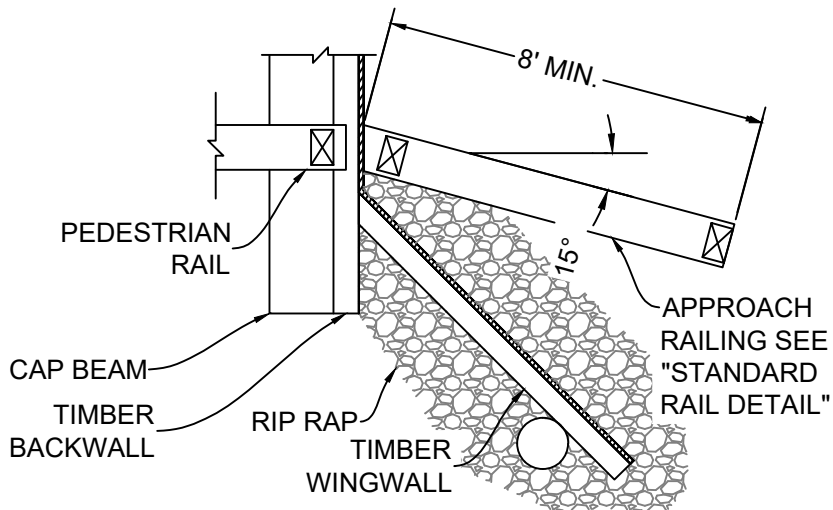

TYPICAL APPROACH RAIL PLAN (TOP VIEW)

NOTES:

1. ALL FENCE MATERIAL SHALL MEET THE REQUIREMENTS OF SECTION 1050 OF THE NCDOT STANDARD SPECIFICATIONS.
2. GALVANIZE ALL STEEL PARTS AND HARDWARE IN ACCORDANCE WITH ARTICLE 1079 OF THE NCDOT STANDARD SPECIFICATIONS.
3. ALL CHAIN LINK FENCE FABRIC, POSTS, RAILS, FITTING HARDWARE, AND ACCESSORIES SHALL BE BLACK VINYL COATED IN ACCORDANCE WITH ARTICLE 1050 OF THE NCDOT STANDARD SPECIFICATIONS.
4. PROVIDE A MINIMUM OF 2 FEET OF RIP RAP AROUND THE TIMBER WINGWALL TO PREVENT WASHOUT OF EARTH MATERIALS.
5. APPROACH RAIL TO BOARDWALKS SHALL BE A MINIMUM OF 8 FEET IN LENGTH, FLARED TO PROVIDE A 2-FOOT LATERAL OFFSET.