

SIGN PLACEMENT

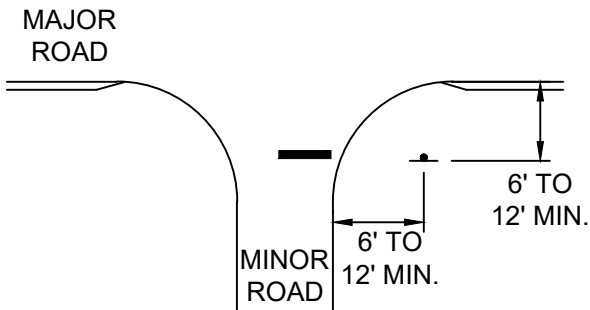

SIGN MOUNTING DETAIL

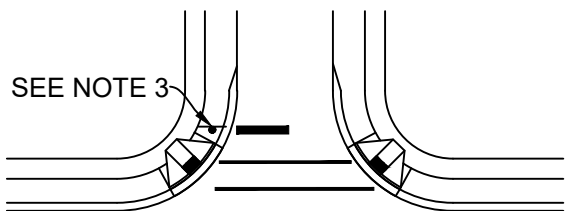
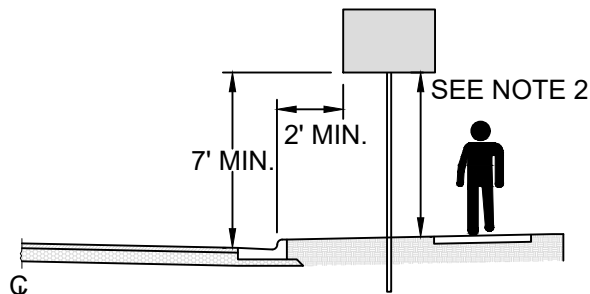
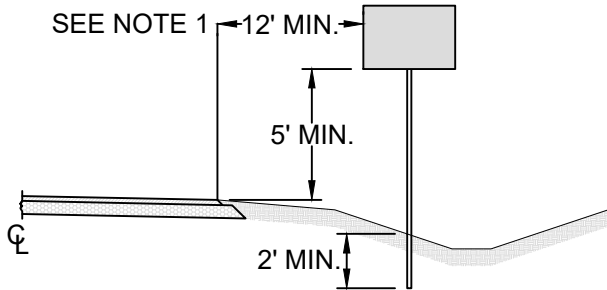
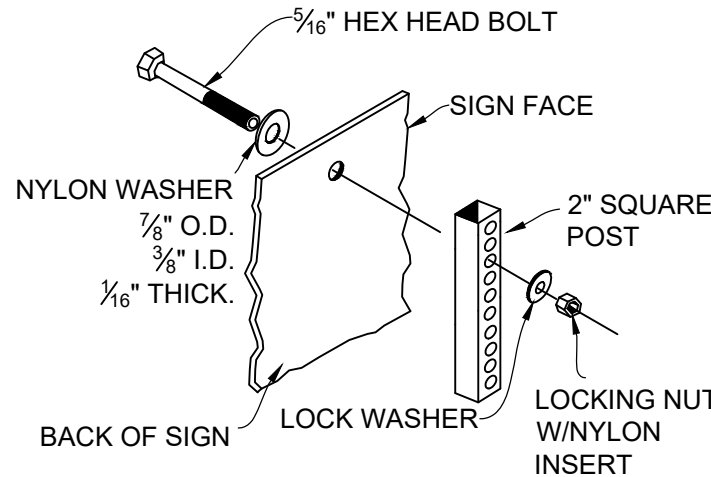

RETROFIT ASSEMBLY DETAIL (TOWN USE ONLY)

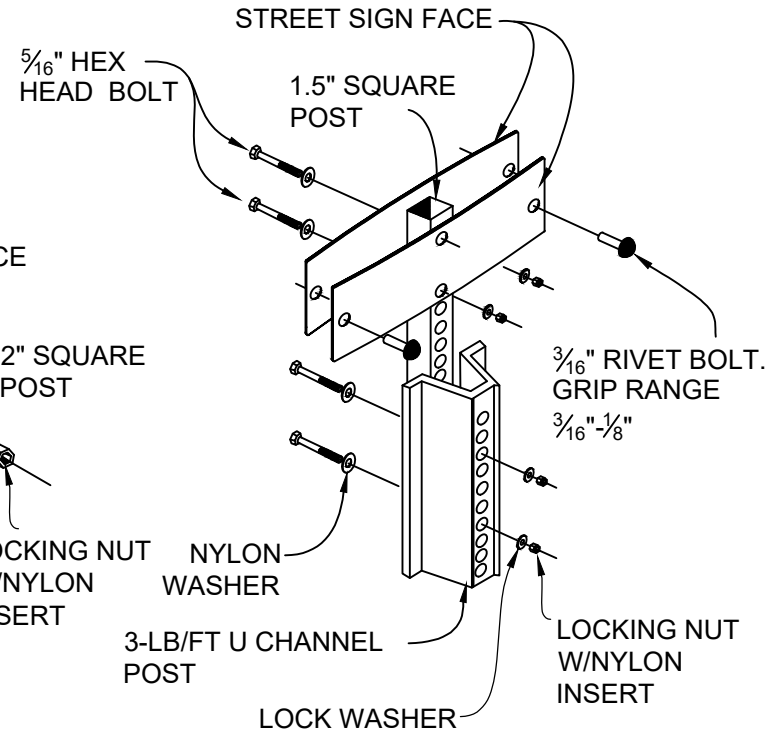

NOTES:

1. MINIMUM LATERAL OFFSET FROM EDGE OF TRAVELED WAY SHOULD BE 12 FEET.
2. ON CURB SECTIONS PROVIDE A MINIMUM VERTICAL CLEARANCE OF 7 FEET FROM EDGE OF TRAVELED WAY. WHERE SIDEWALKS ARE PRESENT PROVIDE A MINIMUM VERTICAL CLEARANCE OF 7 FEET FROM EDGE OF TRAVELED WAY OR TOP OF SIDEWALK, WHICHEVER IS HIGHER.
3. WHERE CROSSWALKS EXIST, SIGNS SHOULD BE PLACED WITHIN 4 FEET IN ADVANCE OF THE CROSSWALK. STREET NAME SIGNS MAY BE PLACED ABOVE A REGULATORY STOP OR YIELD SIGN WITH NO REQUIRED VERTICAL SEPARATION.
4. ALL NEW SIGNS SHALL BE POSTED ON 14 GAUGE, 2" PERFORATED SQUARE SIGN POSTS. ALL STREET NAME SIGNS RETROFITTED TO EXISTING U-CHANNEL SHALL BE POSTED ON 1.5" SQUARE SIGN POSTS. SIGN RETOROFITTING SHALL BE FOR TOWN USE ONLY.
5. ON ALL ROADWAYS EXCEPT STREETS WITH STANDARD CURB AND GUTTER AND SPEED LIMITS EQUAL TO OR LESS THAN 25 MPH, ALL SIGNS WITHIN CLEAR ZONE SHALL BE OF A BREAKAWAY DESIGN THAT COMPLIES WITH THE LATEST EDITION OF AASHTO MANUAL FOR ASSESSING SAFETY HARDWARE (MASH) AND NCHRP REPORT 350.

TOWN OF APEX  
STANDARDS

EFFECTIVE: NOVEMBER 19, 2019

STREET SIGNS  
PLACEMENT & INSTALLATION

STD. NO.

300.26

SHEET 2 OF 4