



Town of Apex
Inspections Division:
 919-249-3418
Planning Department:
 919-249-3426

**SOIL EROSION AND SEDIMENTATION CONTROL (S&E)
 INSTALLATION AND MAINTENANCE AGREEMENT
 TO BE SUBMITTED WITH BUILDING PERMIT**

PROJECT NUMBER: _____

STREET NAME: _____ LOT #: _____

SUBDIVISION: _____

ANTICIPATED STARTING DATE OF CONSTRUCTION: _____

Person(s) or Firm(s) who are responsible for this land-disturbing activity:

Owner or Agent's Name: _____

Company Name: _____

Company Address: _____

Telephone Number (field): _____

Telephone Number (office): _____ Ext. _____

Fax Number: _____

Applicant's Signature: _____

THE APPLICANT HEREBY CERTIFIES THAT HE/SHE HAS READ THE INFORMATION ON THE ATTACHED FORMS AND IS AWARE OF THE STATED REQUIREMENTS. THE OWNER MUST COMPLY WITH THE PROVISIONS OF TOWN OF APEX (TOWN) S&E ORDINANCES.

Attachments:

1. Standard Temporary Silt Fence Detail
2. Residential Construction Entrance Detail

The Town Soil & Erosion Ordinance requires that anyone conducting land-disturbing activity control sediment and provide adequate measures to retain sediment at the disturbed site [Section 5-145(b) and section 5-146(5)]. The total disturbed area of the site includes any borrow or waste areas that are used for the residential site. Land-disturbing activities include demolition and land clearing. S&E measures must be installed in accordance with the Town Standard Specification and Standard Details Manual.

A grading fee of \$500 per disturbed acre (no maximum) will be charged. To determine the amount of fee, take the number of planned developed lots, find the average square footage, multiply the average by eighty (80) percent, and multiply by \$500.

Failure to install or maintain erosion control measures will result in civil penalties.

Any questions concerning these requirements should be addressed to Michael Deaton, Director of Water Resources, at 919-249-3413.

EROSION CONTROL OPTIONS

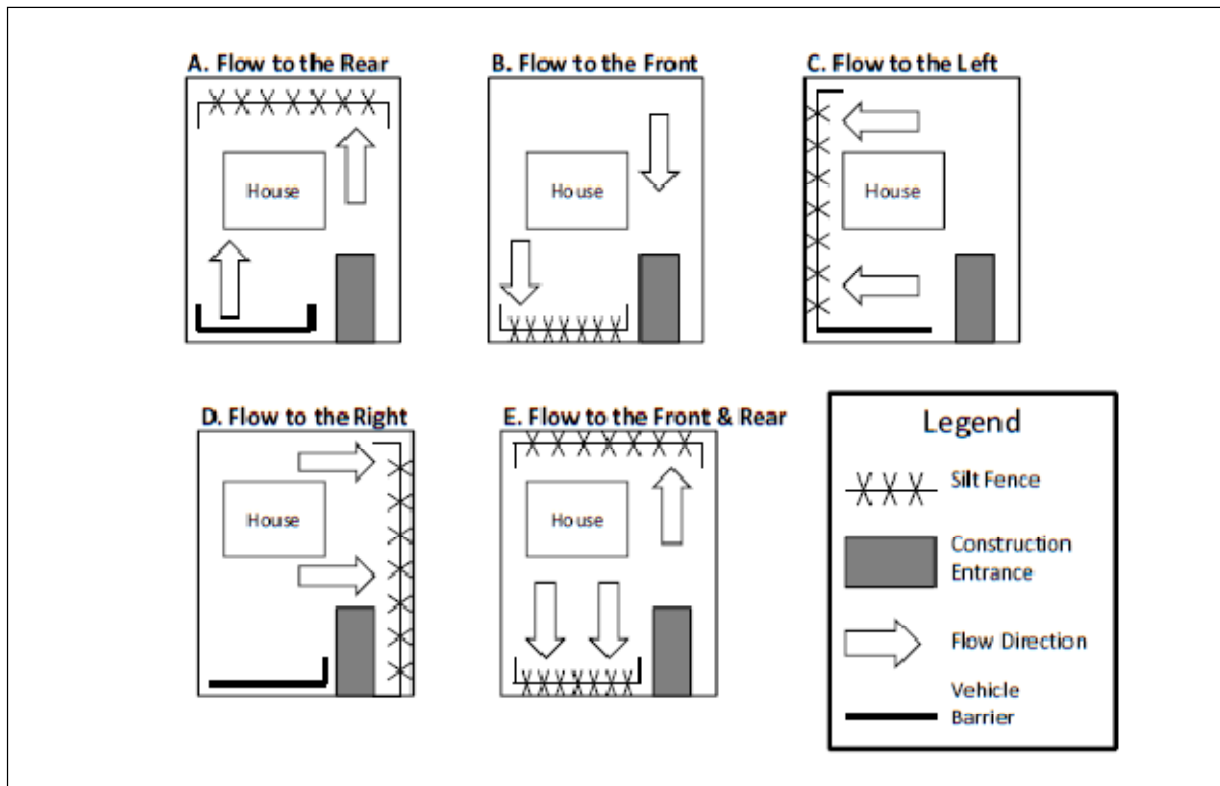

Instructions: Identify one or a combination of options that best describes the erosion control measures that will be used during construction.



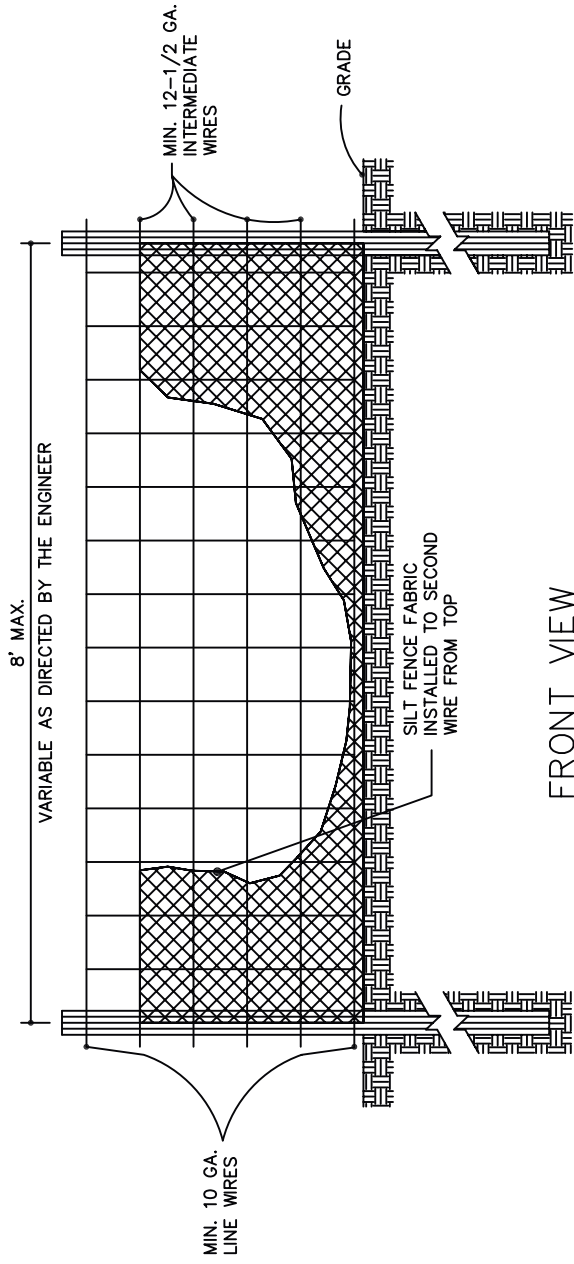

FRONT VIEW

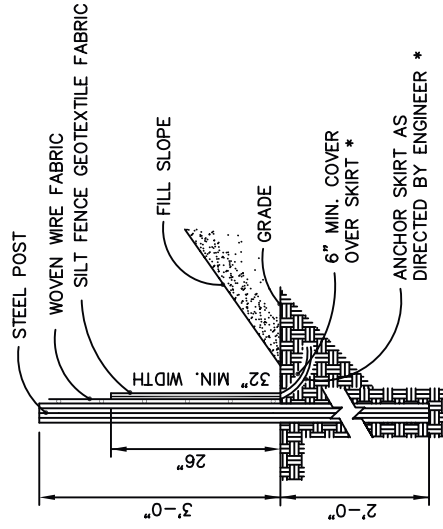

SIDE VIEW

NOTE:

- USE SILT FENCE ONLY WHEN DRAINAGE AREA DOES NOT EXCEED 1/4 ACRE AND NEVER IN AREAS OF CONCENTRATED FLOW
- END OF SILT FENCE NEEDS TO BE TURNED UPHILL.

- * FOR REPAIR OF SILT FENCE FAILURES, USE No. 57 WASHED STONE FOR ANCHOR WHEN SILT FENCE IS PROTECTING CATCH BASIN.

RESIDENTIAL CONSTRUCTION ENTRANCE

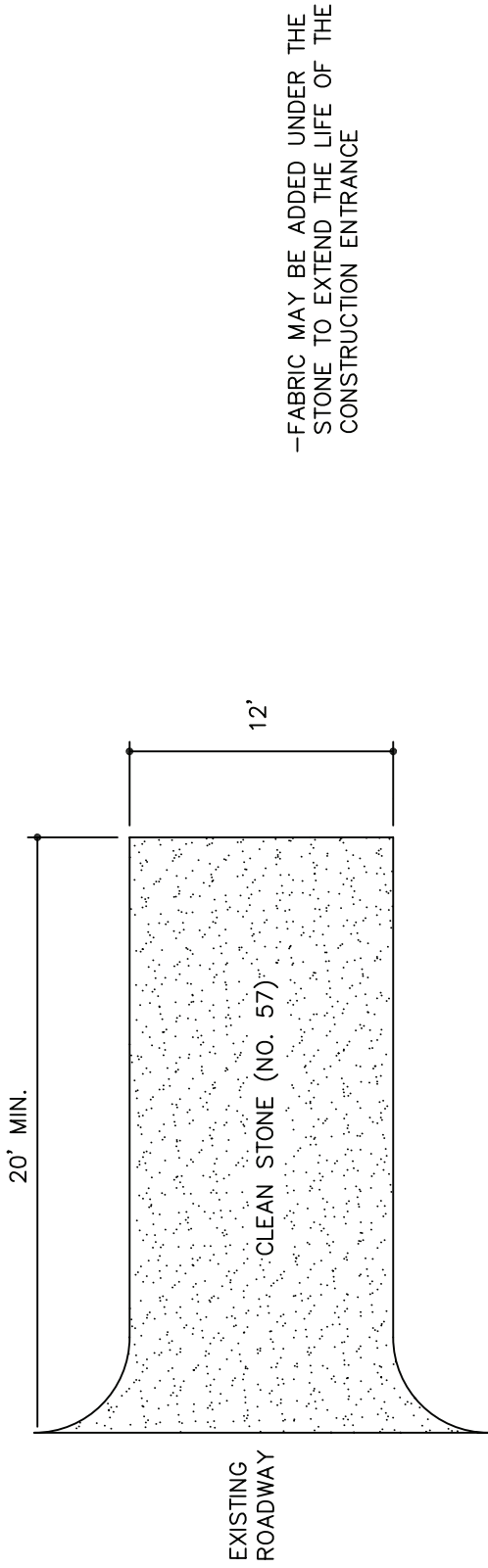

PLAN

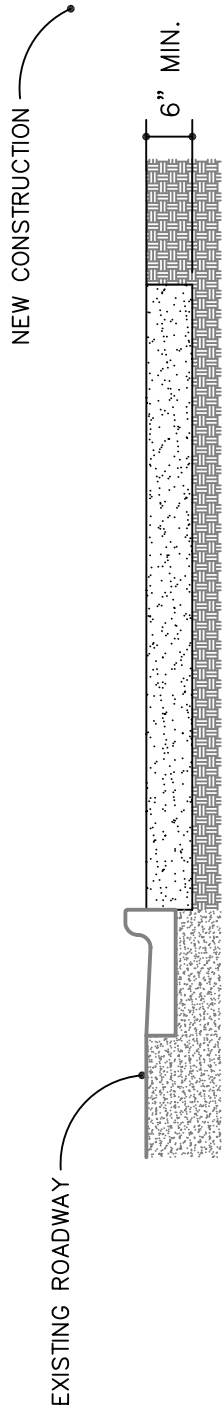

CROSS SECTION

NOTE: THIS ENTRANCE APPLIES ONLY TO ENTRANCES OF INDIVIDUAL SINGLE FAMILY RESIDENTIAL UNITS.