

TOP OF GROUND

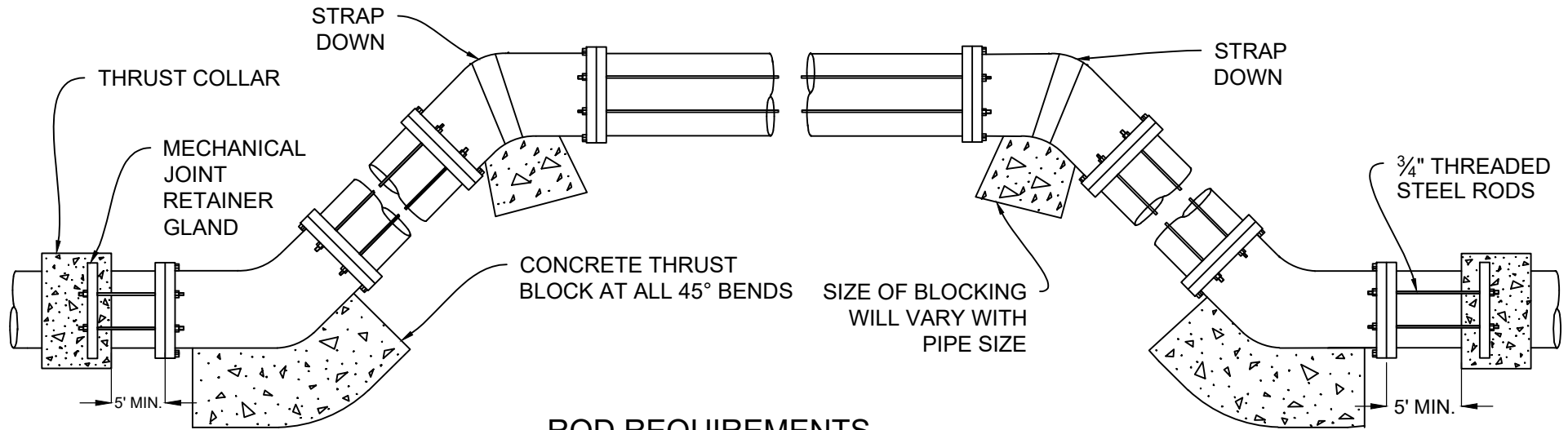

ROD REQUIREMENTS

SIZE OF 45 BEND	STATIC THRUST IN POUNDS	NO. OF RODS REQUIRED
6"	4,328	2
8"	7,694	4
10"	12,503	4
12"	17,312	4
14"	24,046	6
16"	30,779	8
18"	50,016	8
24"	69,252	8

NOTES:

1. STEEL RODS AND BOLTS SHALL BE 3/4" HOT DIPPED GALVANIZED.
2. CONCRETE SHALL NOT CONTACT BOLTS OR ENDS OF MECHANICAL JOINT BENDS.
3. RESTRAINED MECHANICAL GLANDS TO BE USED AT ALL FITTINGS.
4. MUST USE DUCTILE IRON EYE BOLTS WHERE NECESSARY.
5. 3' MINIMUM COVER MUST BE MAINTAINED ON ALL MAINS.
6. ADD MECHANICAL JOINT RETAINER GLANDS THROUGHOUT ASSEMBLY.

**TOWN OF APEX
STANDARDS**

VERTICAL BEND

STD. NO.

450.08

EFFECTIVE: MARCH 23, 2021

SHEET 1 OF 1